

HEMI

GEN III PARTS

Let Indy Convert You. We Make Carbureting Your Gen III Hemi A Walk In The Park!



5.7 / 6.1 Mod Man With 2 x 4 Top



Indy Polished Valve Covers, Spark Plug Wires, And MSD Hemi 6 Ignition Module

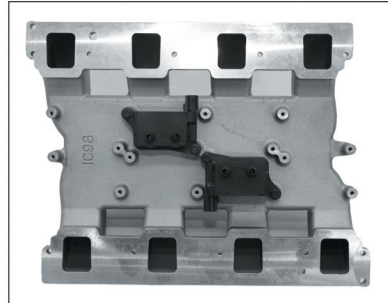

Bottom View Mod Man With Coil Packs Installed

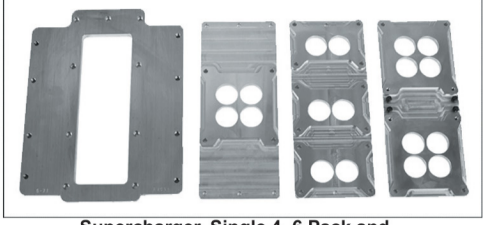

Supercharger, Single 4, 6 Pack and 2 x 4 Tops For 4150 Throttle Bodies

By combining our Mod Man intake, MSD Hemi 6 ignition module, valve covers and spark plug wires you can have your carbureted Gen III Hemi running in no time.



Drag Pak Intake manifold

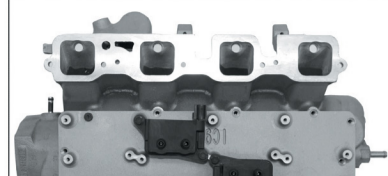

Bottom view Of Stock SRT8 Manifold With Indy's Hidden Coil Adaptor Plate And Coil Packs Installed



New 426" Gen III Short Block

- Machined cast iron 6.1 block
4.090" bore
Billet main caps
Compstar crank
Compstar H Beam rods
Mahle coated pistons (10.3 to 1)
Rings, bearings, internal balanced
ARP main and head studs
Assembled
Custom short blocks available...call
Aluminum 6.1 blocks available

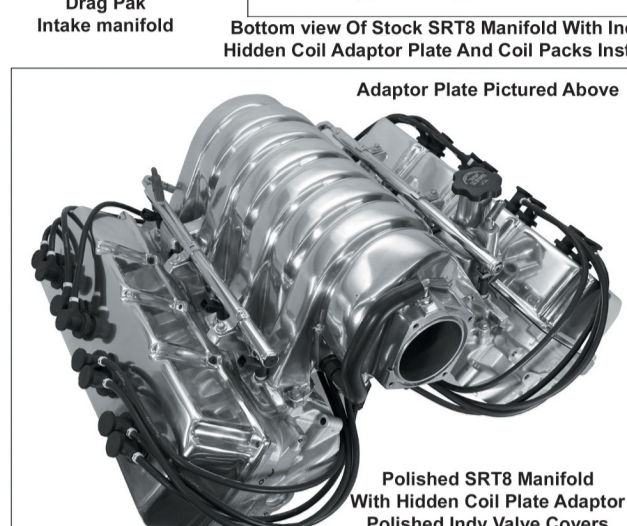

Adaptor Plate Pictured Above

New Legend Rotating Kit

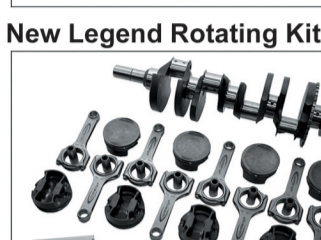

- Compstar crank (4.050" x 2.100)
Compstar H Beam rods(6.125 x .927)
Mahle coated pistons (10.3 to 1)
Rings, bearings
Internal balanced
Manley kits available

We also offer complete crate motors, assembled short blocks and rotating kits, for the 392 / 5.7 and 426 / 6.1 ... see the price sheet for all the details and cost.

Check out these Indy Features

Grid of 6 images showing engine features: 4.050" stroker cranks, dual keys for harmonic damper, 4.050" stroking kit, steel billet main caps, 4340 material crankshafts, and art 5 axis porting.

Call: 317-862-3724 Fax: 317-862-6300 Web: indyheads.com Email: techline@indyheads.com

GEN III PARTS

HEMI



392 / 426 New Hemi Parts For The 5.7 / 6.1

We carry an extensive line of parts for the new 392 / 426 Hemi. See the price guide for a full listing:

- Billet main caps
Main studs
Head studs
Compstar cranks
Compstar H-Beam rods
Mahle coated pistons
Rod bearings
Main bearings
Balancers
Head gaskets
Polished beehive springs
Titanium retainers
Chrome moly push rods
Oil pumps
Oil pans
Fast fuel injection kits
TTI headers

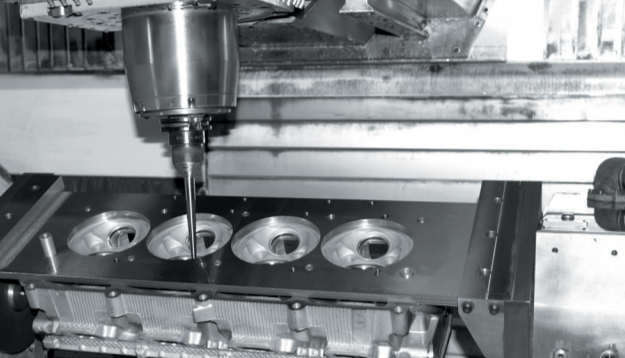

Gen III Hemi Gaskets

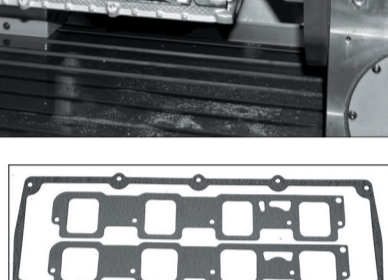

ATI Balancer

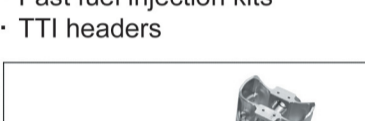

Mahle Coated Pistons Compstar Rods



Diamond Pistons And Manley Rods Also Available



Indy Hi Volume Blue Printed Oil Pump



Gen III Hemi Engine Mounts For Your Classic Mopar

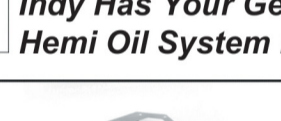

Milodon Windage Tray And Gaskets



Milodon Pan And Pick Up For Drag Pak And Bracket Race Applications



Milodon Pan And Pick Up For Most Classic Mopars



ECU Wiring Harness



Head Bolts And Studs



Indy Has Your Gen III Hemi Oil System In Stock



Milodon Windage Tray And Gaskets

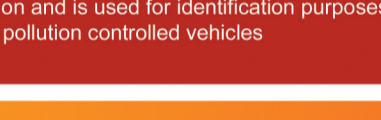

Milodon Pan And Pick Up For Drag Pak And Bracket Race Applications



Milodon Pan And Pick Up For Most Classic Mopars

Call: 317-862-3724 Fax: 317-862-6300 Web: indyheads.com Email: techline@indyheads.com

426-6.1/5.7 New Legend Hemi

6.1 Hemi Power with Old School Looks & Carburetion Without the \$4,000.00 computer! \$6,995.00. Includes 400hp, 375 torque, 6.1 short block, 5.7 heads, hydraulic roller cam, mod man 2/4 intake, 500 CFM carbs, hidden coils, firecore wires, indy cast valve covers, milodon center sump pan, msd complete ignition control.

Drag Pack Engines & Parts. Includes 6.1 Hemi Drag Pack Intake (\$995.00), Drag Pack Short Block (\$4,995.00), Drag Pack Injectors (\$400.00), ATI Balancer For Drag Pack Engine (\$465.00), 5.7" OD Diamond Piston Kit (\$1,300.00), Double Roller Timing Chain Kit (\$199.00), Hydraulic Roller Lifters (\$380.00), etc.

426-6.1/5.7 New Legend Hemi

Indy 6.1/5.7 Mod Man Intake - The modular single plane horsepower manifold! It's very versatile. Includes 5.7/6.1 Valve Covers (\$499.00), 426 CU IN / 6.1 Short Block (\$3,995.00), 392 CU IN / 5.7 Short Block (\$3,499.00), 5.7/6.1 Rotating Kit (\$2,250.00), 5.7/6.1 Hemi Car Pan (\$175.00), 5.7/6.1 Drag Pack or Bracket Race (\$320.00), 5.7/6.1 Windage Tray (\$80.00), Firecore Plug Wires (\$320.00), etc.